

**PARTS FOR FIRETAK MODEL #FT10101 HANDPUMP**

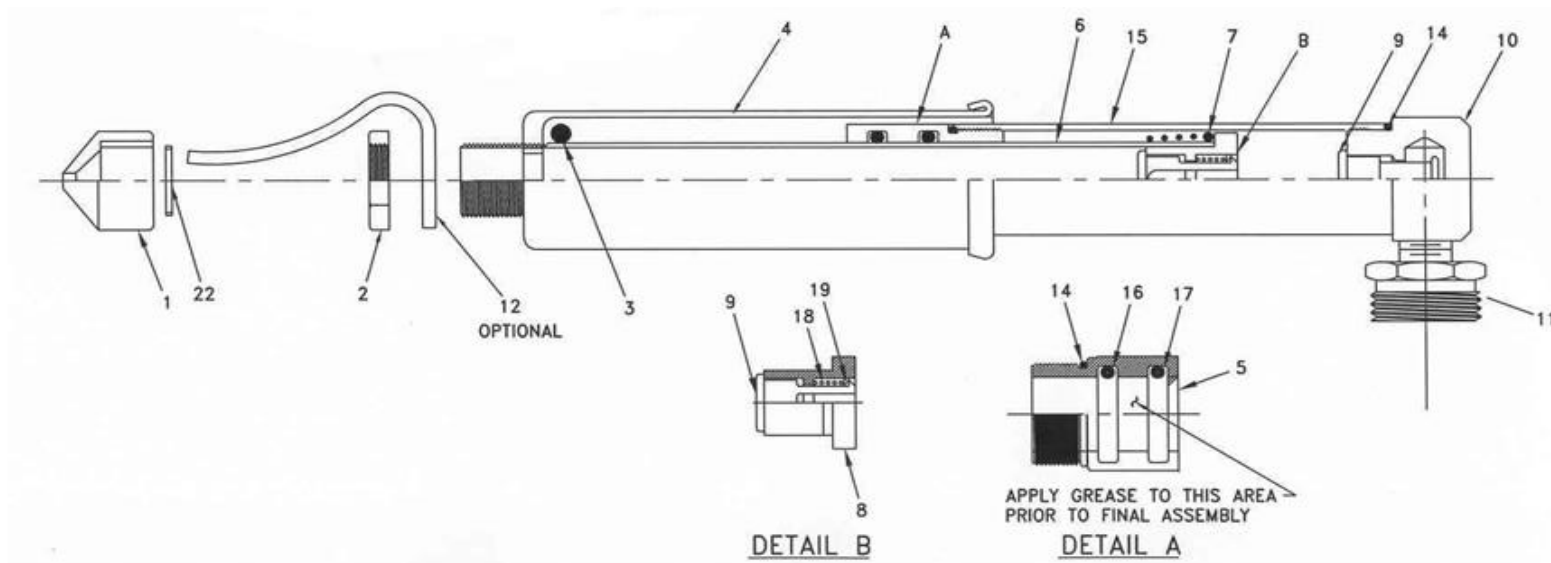

**"O" Ring Kit – Model #10100**

<u>ITEM #</u>	<u>PART #</u>
3 (1 per pump)	FT10113
14 (2 per pump)	FT10107
16 (1 per pump)	FT10119
17 (1 per pump)	FT10108

<u>ITEM #</u>	<u>PART #</u>	<u>DESCRIPTION</u>
1 & 22	FT10122	Nozzle c/w washer
2	FT10112	Locknut
3	FT10113	"O" Ring
*5		Glandnut Body
7	FT10117	Spring
**8		Valve Body
12	FT10038	Deflector
14	FT10107	"O" Ring
16	FT10119	"O" Ring
17	FT10108	"O" Ring
23	FT10030	D-Rings & Strap (2) (Not Shown)
* DETAIL A	FT10115	Glandnut Body Assembly c/w 5, 14, 16 & 17
** DETAIL B	FT10104	Valve Body Assembly c/w 8, 9, 18 & 19
DETAIL C	FT10120	Tail End Assembly c/w 9, 10, 11, 13 & 14